

PREVAIL 



Digital Active DAS

Product Catalog

SHENZHEN PREVAIL TECHNOLOGY CO., LTD.



Penta Band-adjustable Digital DAS (Direct Coupling)

Model: 44325D (44325D.713828Z)

Product Features:

- Support multi-band system.
- Digital bandwidth-adjustable features allow for seamless adaptability to different frequency bands.
- Optical transmission up to 10km (max.).
- Support OMS Lite local/remote control.
- Low noise and high reliability.
- Each master unit can support max.8 remote units.
- Support to monitor donor signal parameters for easy optimization and troubleshooting.



Application Scenario:

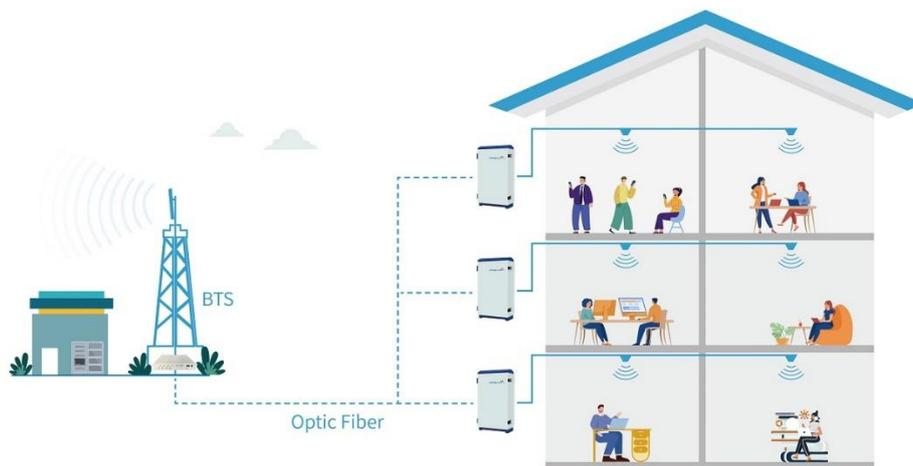

Block Diagram:

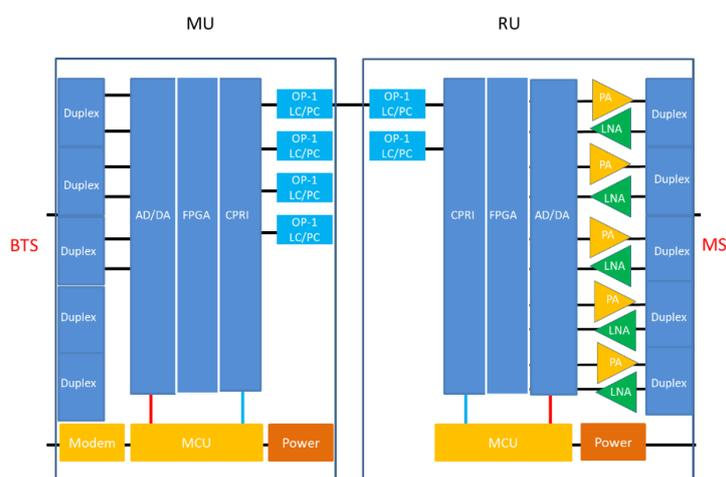



Technical Specifications:

P/N: 44325D.713828Z		MU	RU
Frequency Range	B28 (700) Uplink	703 - 748 MHz (adjustable)	703 - 748 MHz (adjustable)
	B28 (700) Downlink	758 - 803 MHz (adjustable)	758 - 803 MHz (adjustable)
	B8 (900) Uplink	880 - 915 MHz (adjustable)	880 - 915 MHz (adjustable)
	B8 (900) Downlink	925 - 960 MHz (adjustable)	925 - 960 MHz (adjustable)
	B3 (1800) Uplink	1710 - 1785 MHz (adjustable)	1710 - 1785 MHz (adjustable)
	B3 (1800) Downlink	1805 - 1880 MHz (adjustable)	1805 - 1880 MHz (adjustable)
	B1 (2100) Uplink	1920 - 1980 MHz (adjustable)	1920 - 1980 MHz (adjustable)
	B1 (2100) Downlink	2110 - 2170 MHz (adjustable)	2110 - 2170 MHz (adjustable)
	B7 (2600) Uplink	2490 - 2550 MHz (adjustable)	1920 - 1980 MHz (adjustable)
	B7 (2600) Downlink	2630 - 2690 MHz (adjustable)	2110 - 2170 MHz (adjustable)
Number of Sub-bands		5*1	5*1
Bandwidth (per sub-band)	B28 (700)	0.2 - 20 MHz (adjustable)	0.2 - 20 MHz (adjustable)
	B8 (900)	0.2 - 20 MHz (adjustable)	0.2 - 20 MHz (adjustable)
	B3 (1800)	0.2 - 20 MHz (adjustable)	0.2 - 20 MHz (adjustable)
	B1 (2100)	0.2 - 20 MHz (adjustable)	0.2 - 20 MHz (adjustable)
	B7 (2600)	0.2 - 20 MHz (adjustable)	0.2 - 20 MHz (adjustable)
Number of Units		1	≤ 8
Max. Gain		≥ 55 ±3dB	
Manual Gain Control		31 dB in step of 1 dB	
Automatic Gain Control		≥20 dB	
Gain Flatness		≤ 6 dB (peak-to-peak)	
Max. Input Power Without Damage	Uplink	-100 dBm	
	Downlink	-10 dBm	
Output Power	Uplink	-10 ±2dBm per band	
	Downlink	43 ±2dBm per band	
Noise Figure		UL: ≤ 6 dB (Except for central frequency point)	
EVM		≤8%	≤8%
VSWR		≤ 1.8	
System Delay		≤15 μs	
RF Connector		5*N-Female	
Impedance		50Ω	
Optical Output Power		≥0 dBm	
Optical Wavelength		1310 nm/1550 nm (WDM)	
Fiber		Single Mode	
Fiber Connector		4*FC/APC	1*FC/PC
Power Supply		DC -48 V	AC110/220V
Power Consumption		≤75 W	≤ 485 W
Dimensions		422*352*44 mm	813*416*187 mm



Weight		≤ 15 kg	≤ 50 kg
IP Rating		IP40	IP65
Operating Temperature		-10~50 °C	-25~55 °C
NMS	Local	Via Type-C/Wi-Fi App	
	Remote	Via Cloud-based NMS (optional)	

Technical specification is subject to change without prior notice.



Triple Band-adjustable Digital DAS (Direct Coupling)

Model: 44323D (44323D.245Z)

Product Features:

- Support multi-band system.
- Digital bandwidth-adjustable features allow for seamless adaptability to different frequency bands.
- Optical transmission up to 10km (max.).
- Support OMS Lite local/remote control.
- Low noise and high reliability.
- Each master unit can support max.8 remote units.
- Support to monitor donor signal parameters for easy optimization and troubleshooting.



Application Scenario:

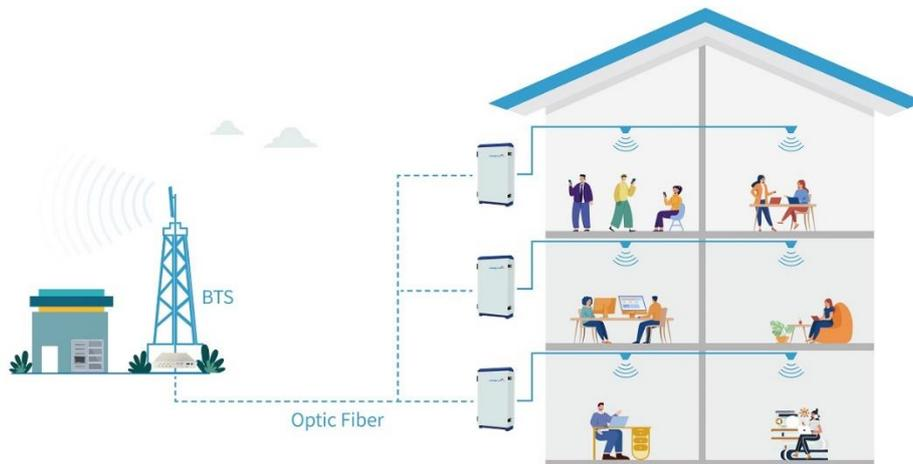

Block Diagram:

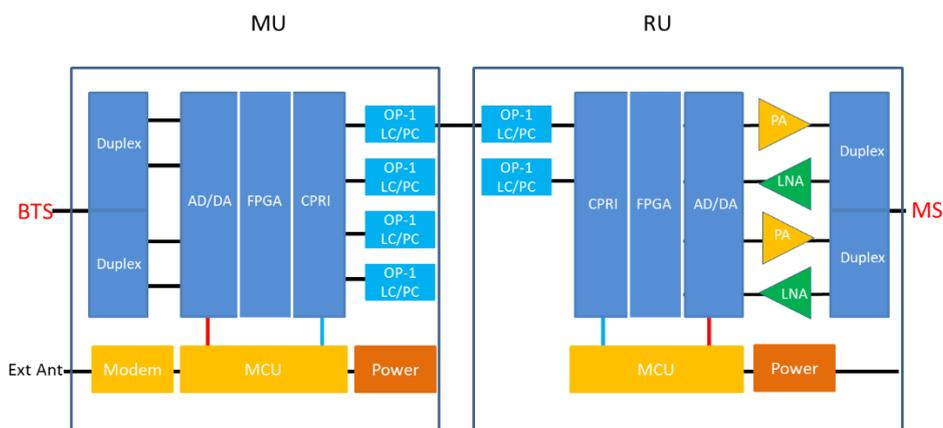



Technical Specifications:

P/N: 44323D.245Z		MU	RU
Frequency Range	B5 (850) Uplink	824 - 849 MHz (adjustable)	824 - 849 MHz (adjustable)
	B5 (850) Downlink	869 - 894 MHz (adjustable)	869 - 894 MHz (adjustable)
	B4 (1700) Uplink	1710-1755 MHz (adjustable)	1710-1755 MHz (adjustable)
	B4 (1700) Downlink	2110-2155 MHz (adjustable)	2110-2155 MHz (adjustable)
	B2 (1900) Uplink	1850 - 1910 MHz (adjustable)	1850 - 1910 MHz (adjustable)
	B2 (1900) Downlink	1930 - 1990 MHz (adjustable)	1930 - 1990 MHz (adjustable)
Number of Sub-bands		3*1	3*1
Bandwidth (per sub-band)	B5 (850)	0.2 - 20 MHz (adjustable)	0.2 - 20 MHz (adjustable)
	B4 (1700)	0.2 - 20 MHz (adjustable)	0.2 - 20 MHz (adjustable)
	B2 (1900)	0.2 - 20 MHz (adjustable)	0.2 - 20 MHz (adjustable)
Number of Units		1	≤ 8
Max. Gain		≥ 55 ±3dB	
Manual Gain Control		31 dB in step of 1 dB	
Automatic Gain Control		≥20 dB	
Gain Flatness		≤ 6 dB (peak-to-peak)	
Max. Input Power Without Damage	Uplink	-100 dBm	
	Downlink	-10 dBm	
Output Power	Uplink	-10 ±2dBm per band	
	Downlink	43 ±2dBm per band	
Noise Figure		UL: ≤ 6 dB (Except for central frequency point)	
EVM		≤8%	≤8%
VSWR		≤ 1.8	
System Delay		≤15 μs	
RF Connector		3*N-Female	
Impedance		50Ω	
Optical Output Power		≥0 dBm	
Optical Wavelength		1310 nm/1550 nm (WDM)	
Fiber		Single Mode	
Fiber Connector		4*FC/APC	1*FC/PC
Power Supply		DC -48 V	AC110/220V
Power Consumption		≤65 W	≤ 385 W
Dimensions		422*352*44 mm	513*416*187 mm
Weight		≤15 kg	≤ 35 kg
IP Rating		IP40	IP65
Operating Temperature		-10~50 °C	-25~55 °C
NMS	Local	Via Type-C/Wi-Fi App	
	Remote	Via Cloud-based NMS (optional)	

Technical specification is subject to change without prior notice.



Dual Band-adjustable Digital DAS (Air-coupling)

Model: 54322D (P/N: 54322D.783K)

Product Features:

- Built-in baseband synchronization module, accurate synchronization.
- Optical transmission up to 10km (max.).
- Support local/remote control.
- Low noise and high reliability.
- Each master unit can support 4 remote units.
- Support to monitor donor signal parameters for easy optimization and troubleshooting.
- Support 2G,3G,4G FDD & 5G TDD Technologies.



Application Scenario:

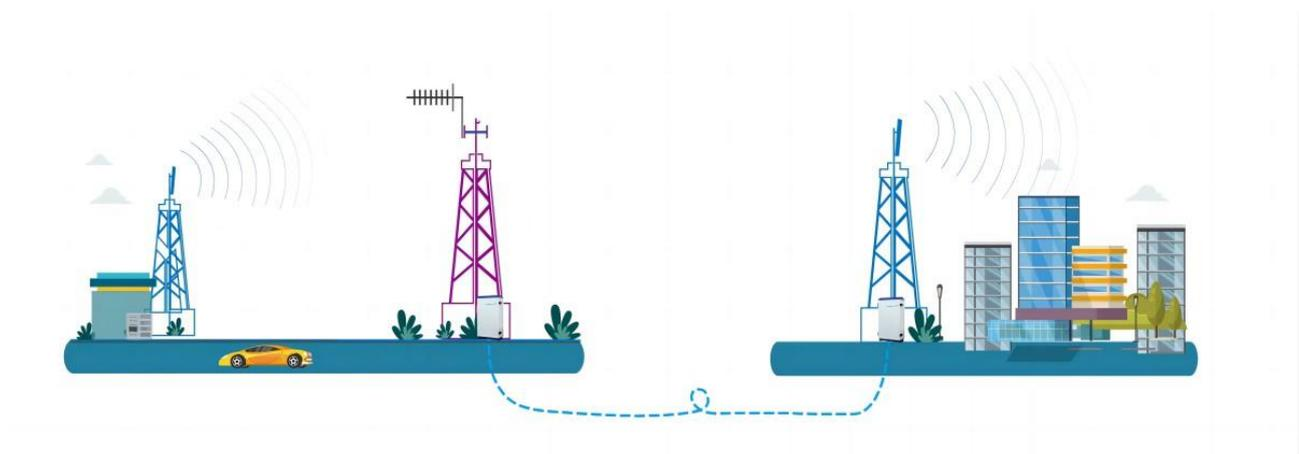

Working Schematic Diagram

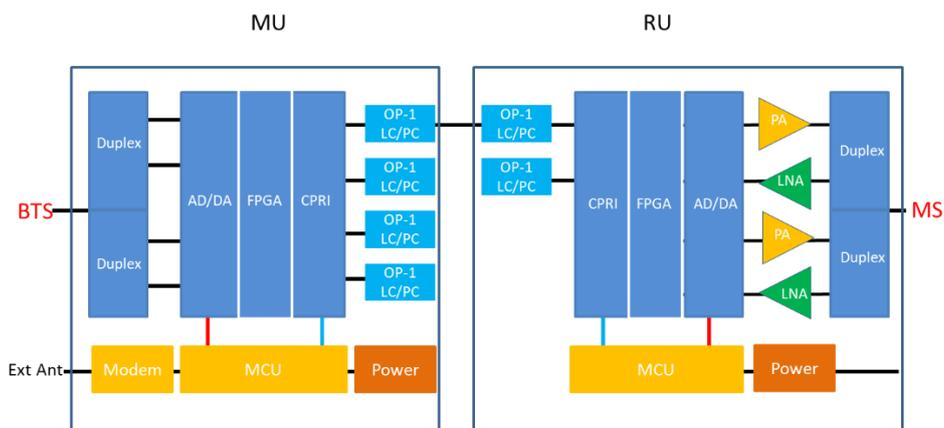



Technical Specifications:

P/N: 53722D.783K		MU	RU
Frequency Range	B3 (1800) Uplink	1710 - 1785 MHz (adjustable)	1710 - 1785 MHz (adjustable)
	B3 (1800) Downlink	1805 - 1880 MHz (adjustable)	1805 - 1880 MHz (adjustable)
	N78 (3500) Uplink	3490 - 3800 MHz (adjustable)	3490 - 3800 MHz (adjustable)
	N78 (3500) Downlink	3490 - 3800 MHz (adjustable)	3490 - 3800 MHz (adjustable)
Bandwidth	B3 (1800)	≤ 20 MHz (adjustable)	≤ 20 MHz (adjustable)
	N78 (3500)	≤ 100 MHz (adjustable)	≤ 100 MHz (adjustable)
Number of Units		1	≤ 4
Max Gain		90 \pm 2dB	
Manual Gain Control		31 dB in step of 1 dB	
Automatic Gain Control		≥ 20 dB	
Gain Flatness		≤ 6 dB (peak to peak)	
Max. Input Power without Damage	Uplink	-10 dBm	
	Downlink	-10 dBm	
Output Power	Uplink	27 \pm 2 dBm	
	Downlink	43 \pm 2dBm	
Noise Figure		UL: ≤ 6 dB	
EVM		$\leq 8\%$ @LTE 64QAM / $\leq 3.5\%$ @ NR256QAM	
VSWR		≤ 1.8	
System Delay		≤ 15 μ s	
RF Connector		N-Female	
Impedance		50 Ω	
Optical Output Power		≥ -9 dBm	
Optical Wavelength		1330 nm/1270 nm (DDM)	
Fiber		Single Mode	
Fiber Connector		LC/PC*4	FC/PC*2
Power Supply		AC110~220V	AC110~220V
Power Consumption		≤ 85 W	≤ 245 W
Dimensions		400*595*200mm	400*595*200mm
Weight		≤ 15 kg	≤ 25 kg
IP Rating		IP65	IP65
Operating Temperature		-25~55 $^{\circ}$ C	
NMS	Local	Via Type-C/Wi-Fi App	
	Remote	Via Cloud-based NMS (optional)	

Technical specification is subject to change without prior notice.



Dual Band-adjustable Digital DAS (Air-coupling)

Model: 53722D (P/N: 53722D.78K)

Product Features:

- Built-in baseband synchronization module, accurate synchronization.
- Digital bandwidth-adjustable features allow for seamless adaptability to different frequency bands
- Optical transmission up to 10km (max.).
- Support local/remote control.
- Low noise and high reliability.
- Each master unit can support max.16 remote units.
- Support to monitor donor signal parameters for easy optimization and troubleshooting.
- Support 2G,3G,4G FDD & 5G TDD Technologies.



Application Scenario:

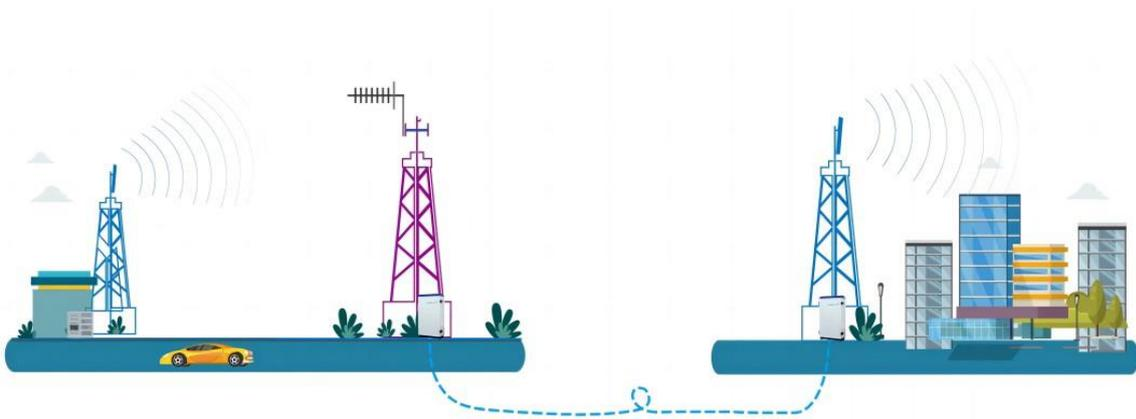

Working Schematic Diagram

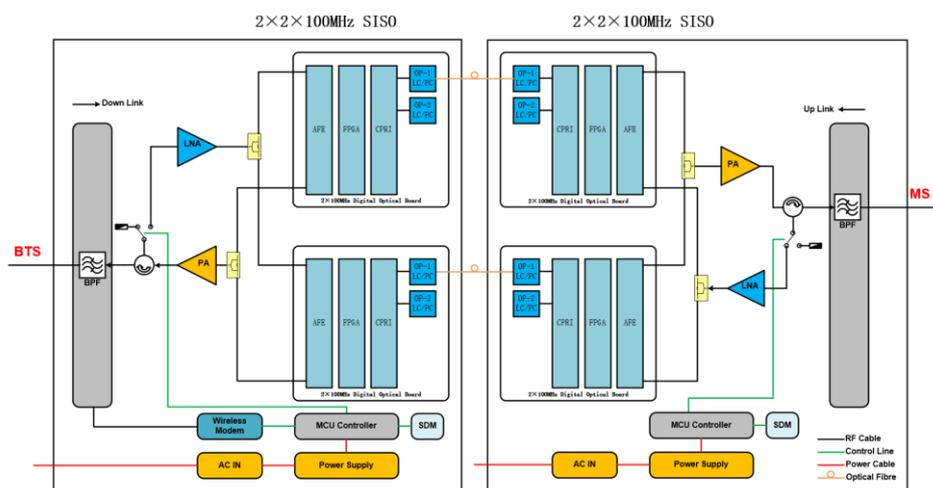



Technical Specifications:

P/N: 53722D.78K		MU	RU
Frequency Range	N78 (3500) Uplink	3400 - 3800 MHz (adjustable)	3400 - 3800 MHz (adjustable)
	N78 (3500) Downlink	3400 - 3800 MHz (adjustable)	3400 - 3800 MHz (adjustable)
	N78 (3500) Uplink	3400 - 3800 MHz (adjustable)	3400 - 3800 MHz (adjustable)
	N78 (3500) Downlink	3400 - 3800 MHz (adjustable)	3400 - 3800 MHz (adjustable)
Number of Sub-bands		2*2	2*2
Bandwidth (per sub-band)	N78 (3500)	5 - 100 MHz (adjustable)	5 - 100 MHz (adjustable)
	N78 (3500)	5 - 100 MHz (adjustable)	5 - 100 MHz (adjustable)
Number of Units		1	≤ 16
Max Gain		90 ± 2dB	
Manual Gain Control		31 dB in step of 1 dB	
Automatic Gain Control		≥ 20 dB	
Gain Flatness		≤ 6 dB (peak to peak)	
Max. Input Power without Damage	Uplink	-10 dBm	
	Downlink	-10 dBm	
Output Power	Uplink	27 ± 2 dBm	
	Downlink	37 ± 2 dBm	
Noise Figure		UL: ≤ 8 dB	
EVM		≤ 3.5%	≤ 3.5%
VSWR		≤ 1.8	
System Delay		≤ 15 μs	
RF Connector		Input: 1*N-Female/Output: 1*N-Female	
Impedance		50Ω	
Optical Output Power		≥ -9 dBm	
Optical Wavelength		1330 nm/1270 nm (DDM)	
Fiber		Single Mode	
Fiber Connector		LC/PC*4	LC/PC*2
Power Supply		AC110~220V	AC110~220V
Power Consumption		≤ 85 W	≤ 295 W
Dimensions		416*268*101mm	400*595*200mm
Weight		≤ 15 kg	≤ 25 kg
IP Rating		IP40	IP65
Operating Temperature		-25~55 °C	
NMS	Local	Via Type-C/Wi-Fi App	
	Remote	Via Cloud-based NMS (optional)	

Technical specification is subject to change without prior notice.



Dual Band-adjustable Digital DAS (Air-coupling)

Model: 43722D (P/N: 43722D.3K)

Product Features:

- Support multi-band system.
- Digital bandwidth-adjustable features allow for seamless adaptability to different frequency bands.
- Optical transmission up to 10km (max.).
- Support OMS Lite local/remote control.
- Low noise and high reliability.
- Each master unit can support max.16 remote units.
- Support to monitor donor signal parameters for easy optimization and troubleshooting..



Application Scenario:

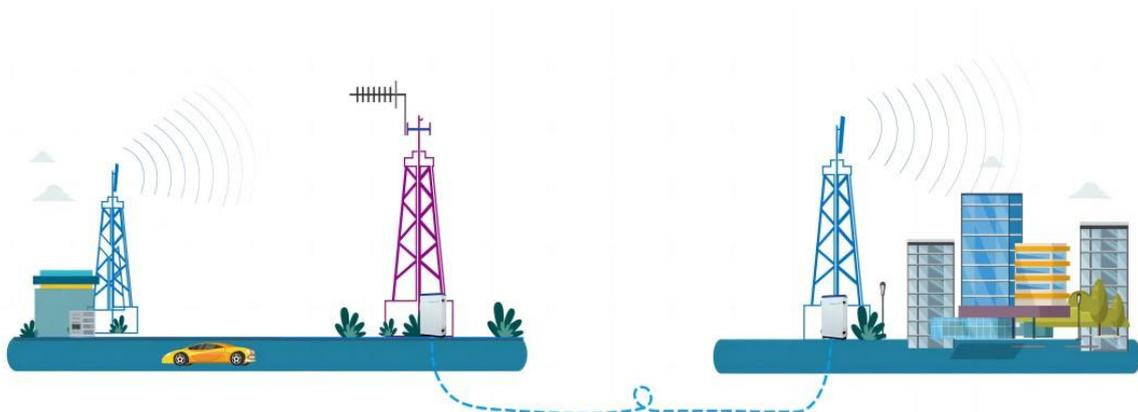

Working Schematic Diagram

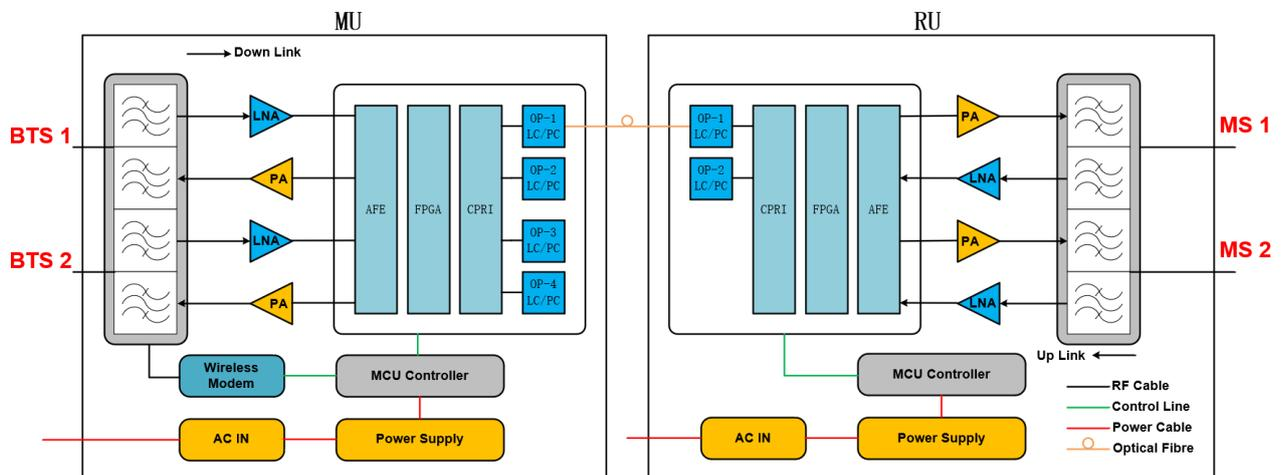



Technical Specifications:

P/N: 43722D.3K		MU	RU
Frequency Range	B3 (1800) Uplink	1710 - 1785 MHz (adjustable)	1710 - 1785 MHz (adjustable)
	B3 (1800) Downlink	1805 - 1880 MHz (adjustable)	1805 - 1880 MHz (adjustable)
	B3 (1800) Uplink	1710 - 1785 MHz (adjustable)	1710 - 1785 MHz (adjustable)
	B3 (1800) Downlink	1805 - 1880 MHz (adjustable)	1805 - 1880 MHz (adjustable)
Number of Sub-bands		2*2	2*2
Bandwidth (per sub-band)	B3 (1800)	0.2 - 20 MHz (adjustable)	0.2 - 20 MHz (adjustable)
	B3 (1800)	0.2 - 20 MHz (adjustable)	0.2 - 20 MHz (adjustable)
Number of Units		1	≤ 16
Max Gain		90 ± 2dB	
Manual Gain Control		31 dB in step of 1 dB	
Automatic Gain Control		≥ 20 dB	
Gain Flatness		≤ 6 dB (peak to peak)	
Max. Input Power without Damage	Uplink	-10 dBm	
	Downlink	-10 dBm	
Output Power	Uplink	27 ± 2 dBm	
	Downlink	37 ± 2 dBm	
Noise Figure		UL: ≤ 6 dB	
EVM		≤ 8%	≤ 8%
VSWR		≤ 1.8	
System Delay		≤ 15 μs	
RF Connector		Input: 2*N-Female/Output: 2*N-Female	
Impedance		50Ω	
Optical Output Power		≥ -9 dBm	
Optical Wavelength		1330 nm/1270 nm (DDM)	
Fiber		Single Mode	
Fiber Connector		LC/PC*4	FC/PC*2
Power Supply		AC110~220V	AC110~220V
Power Consumption		≤ 85 W	≤ 245 W
Dimensions		416*268*101mm	400*595*200mm
Weight		≤ 15 kg	≤ 25 kg
IP Rating		IP40	IP65
Operating Temperature		-25~55 °C	
NMS	Local	Via Type-C/Wi-Fi App	
	Remote	Via Cloud-based NMS (optional)	

Technical specification is subject to change without prior notice.



Shenzhen Prevail Technology Co., Ltd.

1107, Zhongfutai Building, Guangke Road #1, Pingshan District, Shenzhen 518122, China

Tel: +86-755-26466353

Email: info@prevailtec.com

www.prevailtec.com

